

**TO INSERT BATTERIES IN VEHICLES:**

Using a Phillips/cross head screwdriver (not included), loosen screws as shown. Screws will remain attached to undercarriage. Insert 2 x 1.5V "AA" or LR6 size alkaline batteries (not included) Replace undercarriage and tighten screws.

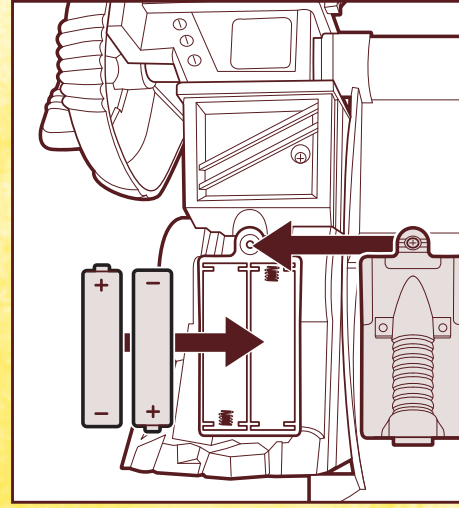
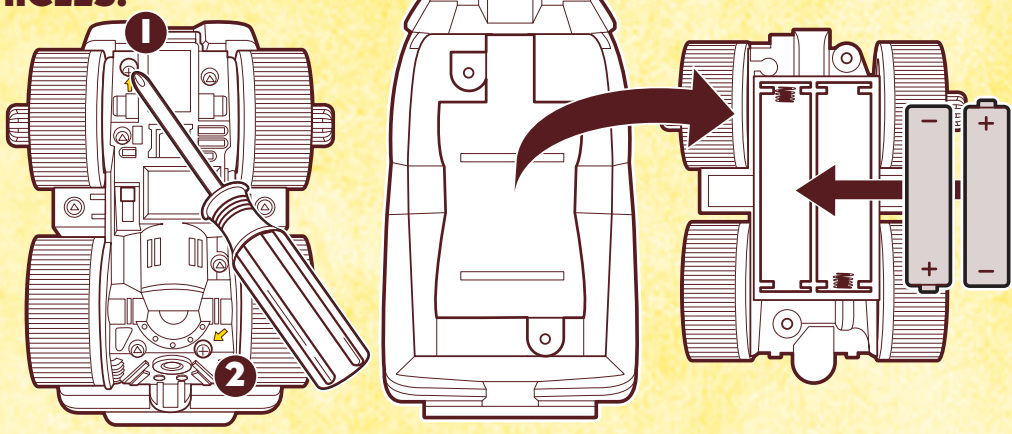

**TO REPLACE BATTERIES IN PLAYSET:**

Using a Phillips/cross head screwdriver (not included), loosen screw in battery compartment cover (screw stays attached to cover). Remove and discard old batteries. Replace with 2 x 1.5V "AA" or R6 size batteries (not included). Alkaline batteries recommended. Replace cover and tighten screw.

**IMPORTANT: BATTERY INFORMATION**

**⚠ CAUTION:**

1. Always follow the instructions carefully. Use only batteries specified and be sure to insert them correctly by matching the + and - polarity markings.
2. Do not mix old batteries and new batteries or standard (carbon-zinc) with alkaline batteries.
3. Remove exhausted or dead batteries from the product.
4. Remove batteries if product is not to be played with for a long time.
5. Do not short-circuit the supply terminals.
6. Should this product cause, or be affected by, local electrical interference, move it away from other electrical equipment. Reset (switching off and back on again or removing and re-inserting batteries) if necessary.
7. RECHARGEABLE BATTERIES: Do not mix these with any other types of batteries. Always remove from the product before recharging. Recharge batteries under adult supervision. **DO NOT RECHARGE OTHER TYPES OF BATTERIES.**

**FCC STATEMENT**

This device complies with part 15 of the FCC Rules. Operation is subject to the following two conditions: (1) This device may not cause harmful interference, and (2) this device must accept any interference received, including interference that may cause undesired operation. This equipment has been tested and found to comply with the limits for a Class B digital device, pursuant to part 15 of the FCC Rules. These limits are designed to provide reasonable protection against harmful interference in a residential installation. This equipment generates, uses and can radiate radio frequency energy, and, if not installed and used in accordance with the instructions, may cause harmful interference to radio communications. However, there is no guarantee that interference will not occur in a particular installation. If this equipment does cause harmful interference to radio or television reception, which can be determined by turning the equipment off and on, the user is encouraged to try to correct the interference by one or more of the following measures:

- Reorient or relocate the receiving antenna.
- Increase the separation between the equipment and receiver.
- Consult the dealer or an experienced radio/TV technician for help.

CAUTION: Changes or modifications to this unit not expressly approved by the party responsible for compliance could void the user's authority to operate the equipment.



**NOTE TO UK CONSUMERS:** This product and its batteries must be disposed of separately at your local waste recycling centre. Do not dispose of in your household waste bin.



Questions? Call: 1-800-327-8264



**AGES 3+**  
28638

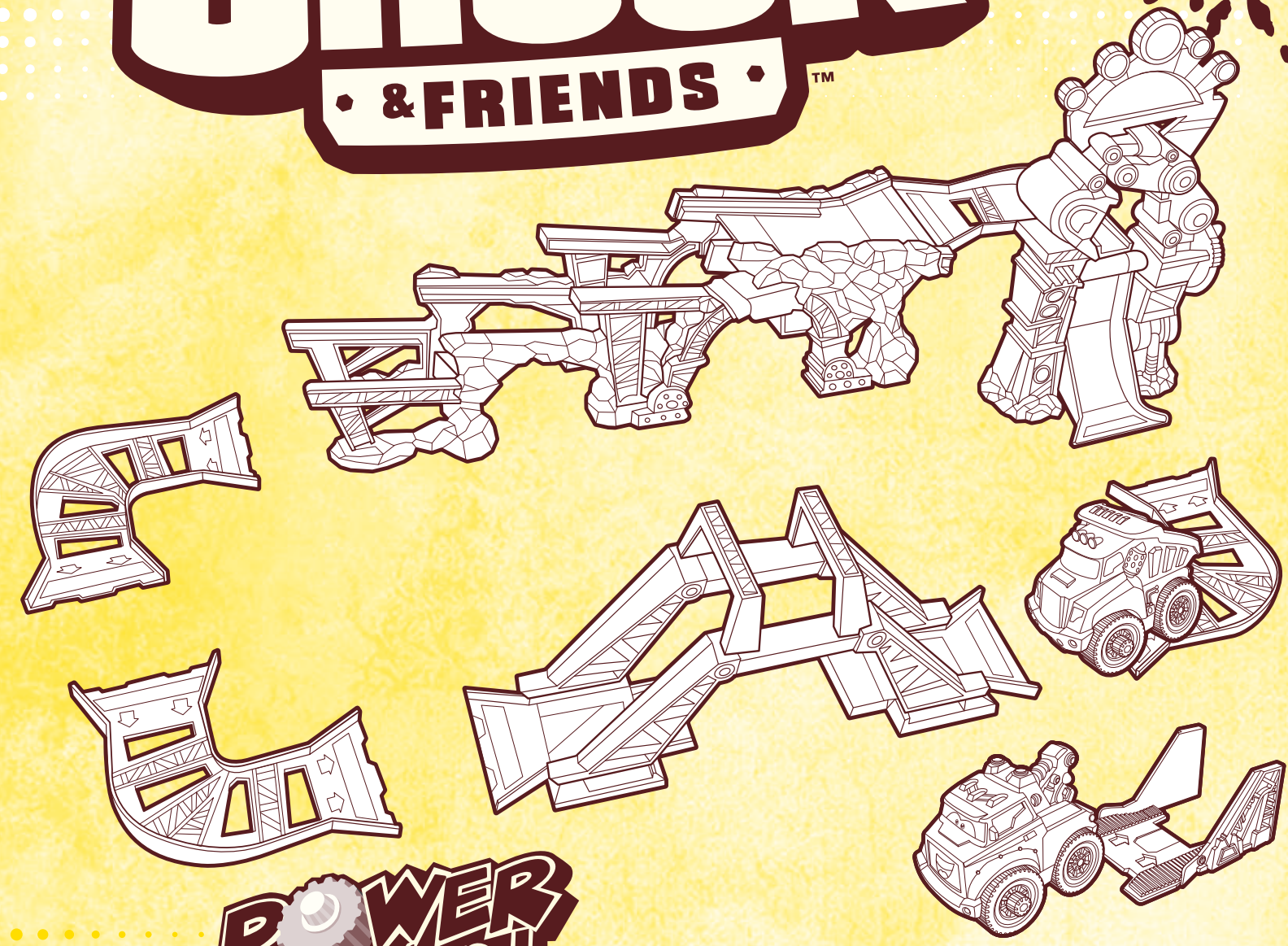

**Chuck's Stunt Park™**

**NOTE:** Adult assembly and Phillips/cross head screwdriver (not included) required.

**For best performance:** Use playset on a hard, smooth surface.

**Vehicle:**



**ALKALINE BATTERIES REQUIRED**  
Phillips/cross head screwdriver (not included) needed to insert batteries.

**Vehicle:**



**ALKALINE BATTERIES REQUIRED**  
Phillips/cross head screwdriver (not included) needed to insert batteries.

**Playset:**



**BATTERIES INCLUDED**  
Replace with 2 x 1.5V "AA" or R6 size batteries. Alkaline batteries recommended. Phillips/cross head screwdriver (not included) needed to replace batteries.

**⚠ CAUTION:**

Hair entanglement may result if child's hair comes in contact with moving parts of toy. Adult supervision is required.



**INCLUDES**

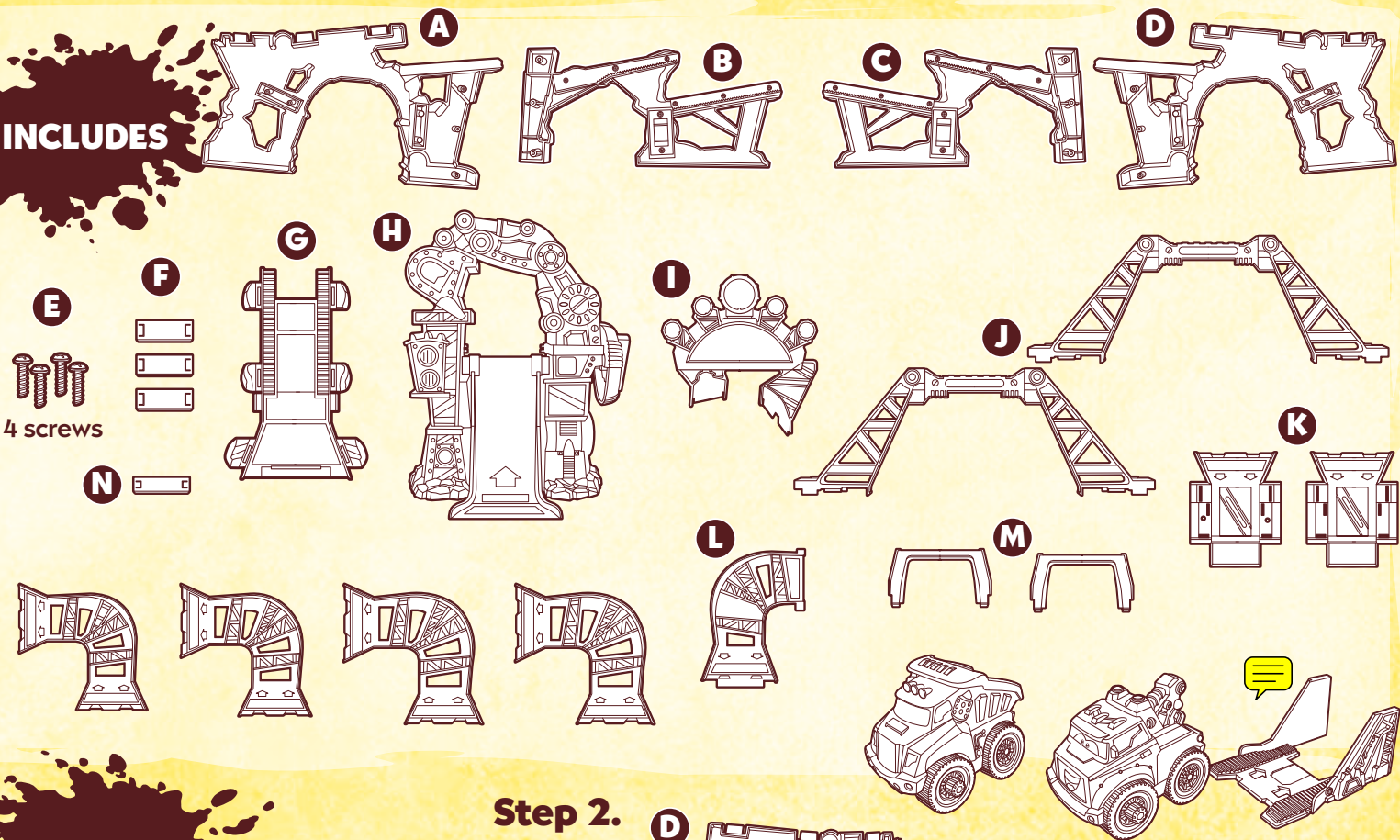

**ASSEMBLY**

Step 1.

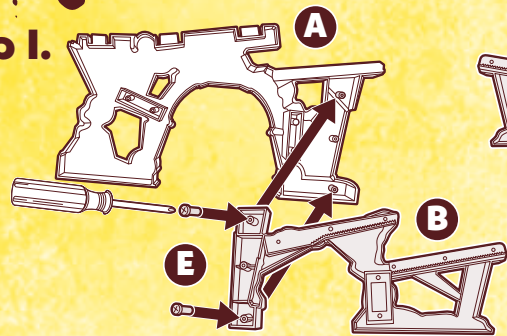

Step 2.

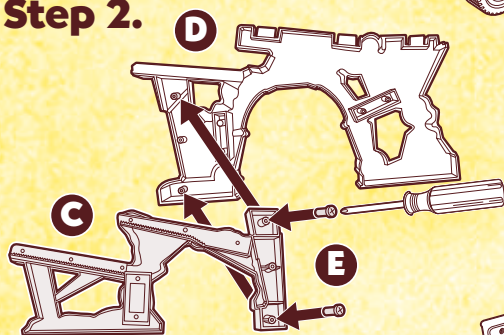

Step 3.

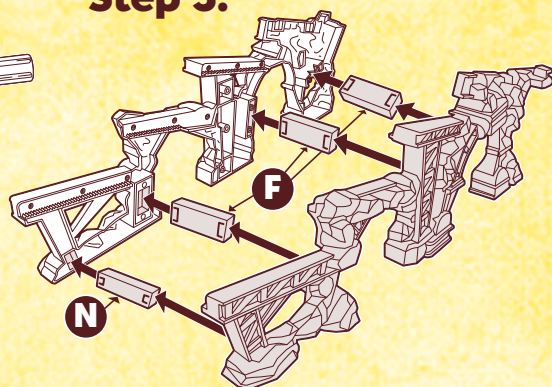

Step 4.

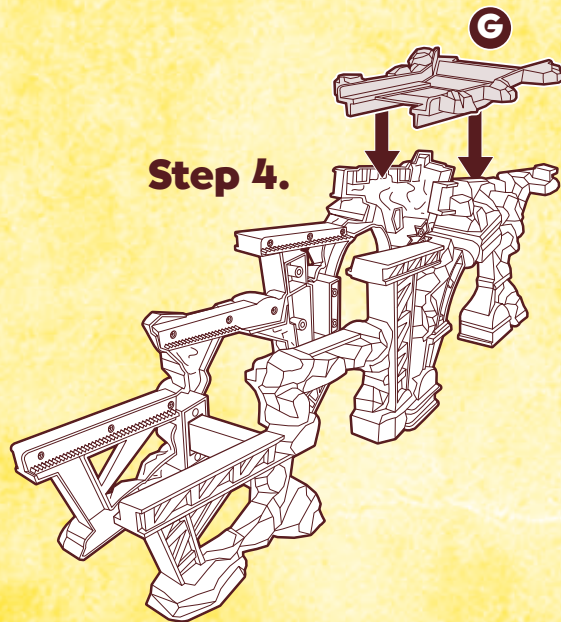

Step 5.

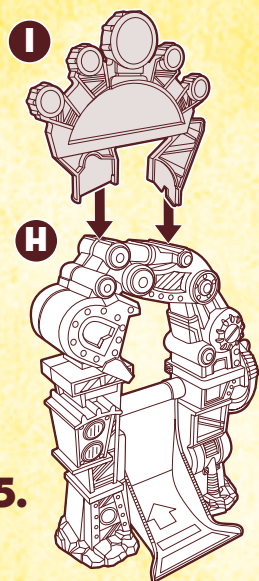

Back side.

Step 6.

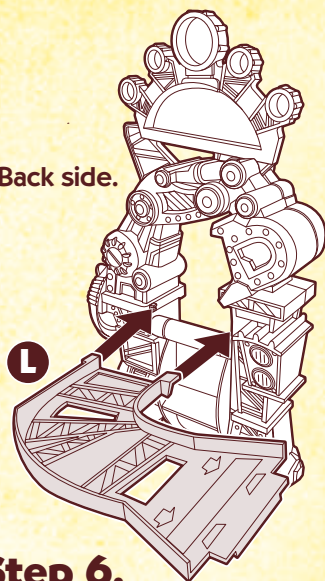

Step 7.

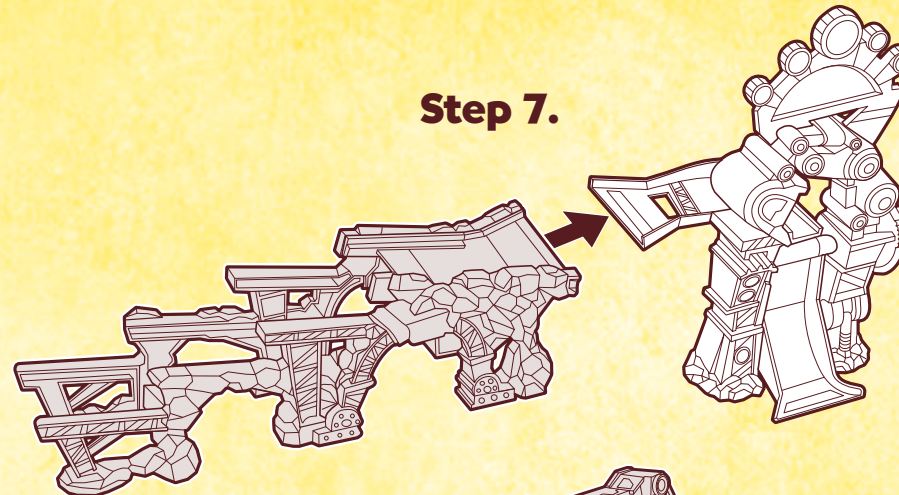

Step 8.

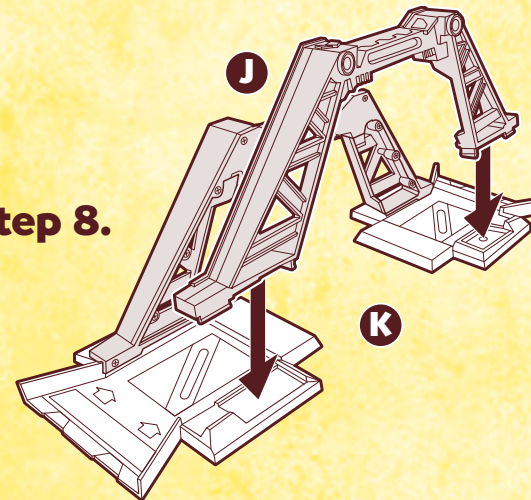

Step 9.

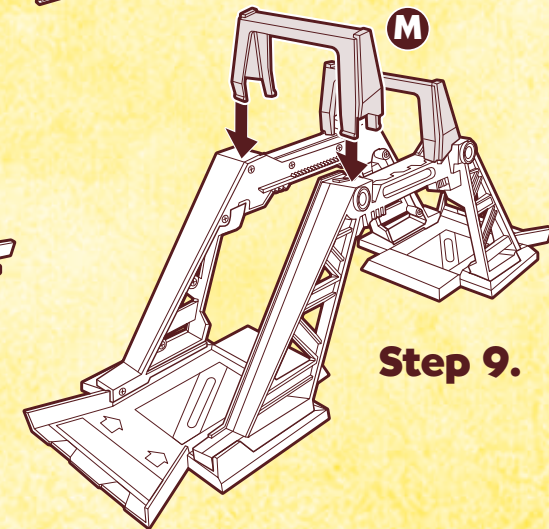

**PLAY**

Here's a fun way to arrange **CHUCK'S STUNT PARK** playset.

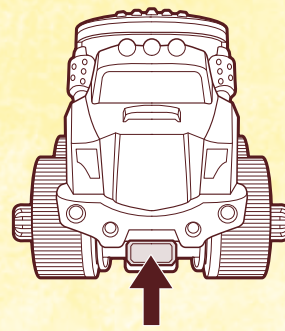

Press the license plate to turn on.

Place the vehicle in the bucket and lift vehicle for lights and sounds.

